

WINCH INSTALLATION INSTRUCTIONS

NOTE: Roller fairlead not included with this kit!

Instructions for '02-'04 Polaris 700 Sportsman, '03-'04 600 Sportsman, '04 500 Sportsman H.O. & '04 400 Sportsman

- 1 – Remove the four top torx bolts from the top rack.
- 2 – Remove the front two rack extension bolts and remove the front rack.
- 3 – Remove the top two rack support bolts and the lower rack support bolts then unplug and remove the light assembly.
- 4 – Remove the center bumper insert.
- 5 – Remove the plastic bumper from the bumper support.
- 6 – Install the fairlead plate with the 5/16 x 1 carriage bolts and nuts up from the bottom and through the plate and winch on the two hole pattern winches.
- 7 – Install the winch fairlead with hardware provided by winch manufacturer.
- 8 – Reinstall the bumper to the machine with original hardware going through winch mount, bumper and into machine.
- 9 – Reinstall rack with it's original hardware.
- 10 – Once all is secure and bumper back in place wire winch to winch manufactures instructions

NOTE: Not all hardware will be used on this installation.

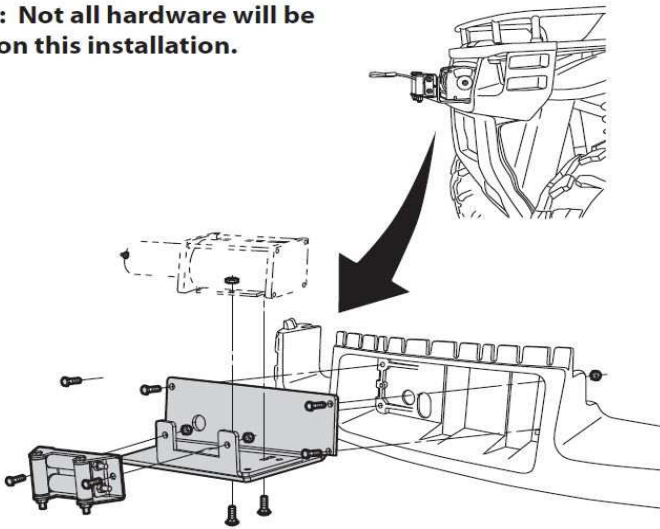

ITEM	PART#	QTY.	DESCRIPTION
1	1601-2	1	Winch Mount Plate
2	1601-2	2	Winch Mount Brackets
3	1591-2	1	Fairlead Plate
4	HDW2000	4	1/4 x 3/4 Hex Bolt
5	HDW2051	4	5/16 x 1 Hex Bolt
6	HDW2064	2	5/16 x 1 Carriage Bolt
7	HDW7050	4	1/4 Nylock Nut
8	HDW7058	6	5/16 Nylock Nut
9	HDW9002	4	5/16 Flat Washer
10	HDW9012	4	1/4 Flat Washer

Instructions for '05-'08 400, 05-10 500, 600, 700 & 800 Sportsman, '06-'07 450 Sportsman, '07-'09 500 & 800 X2

- 1 – Remove the four top torx bolts from the top rack.
- 2 – Remove the front two rack extension bolts and rack.
- 3 – Remove the two top rack support bolts.
- 4 – Remove thee four bumper bolts and unplug the lights
- 5 – Now remove the bumper and light assembly.
- 6 – Remove the center bumper insert.
- 7 – Bolt the two U-shaped winch mount brackets to Frame with the (4) 5/16 x 1 bolts, washers and nylock nuts as shown in illustration.
- 8 – Install the winch mount onto the U-shaped brackets Using the (4) ¼ x ¾ bolts, washers and nylock nuts.
- 9 – Attach winch to plate with the fairlead plate going Between winch and mount aligning the holes to desired location. Bolt to mount winch will come with the winch.
- 10 – Bolt fairlead up to fairlead plate with hardware Provided with winch.
- 11 – Reinstall the bumper going over the winch and mount with original hardware. Reconnect headlights.
- 12 – Wire winch to winch manufactures instructions.

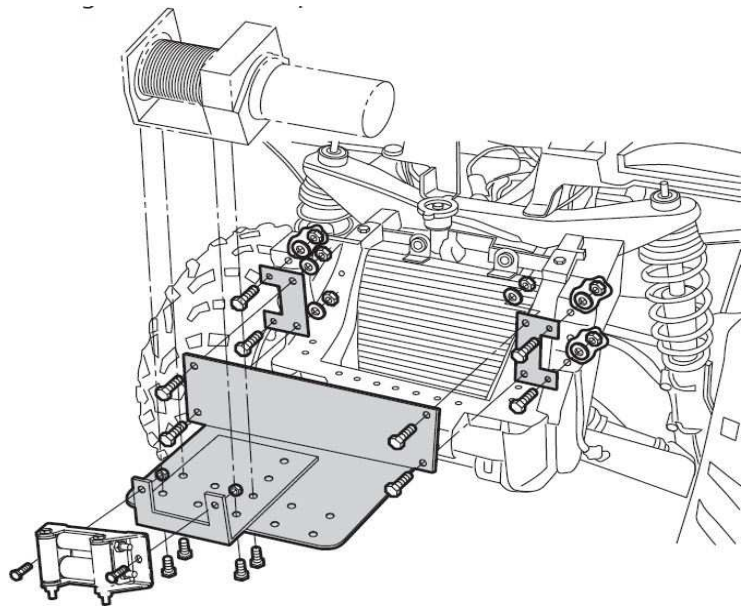

FOR QUESTIONS OR COMMENTS PLEASE CALL: 320-964-1616

INST1601

(Hours are 7:00 to 4:30 CST Monday thru Thursday)