

Winch Mount Instructions

2013-15 Polaris Ranger 900 XP

Ref.	Qty.	Part #	Description
1	1	1606-1	Winch Mount Plate
2	2	1606-2	Fairlead Mount Bracket
3	2	HDW9111	M10 x 35mm Hex Bolts
5	2	HDW2051	5/16" x 1" Hex Bolts
6	2	HDW7058	5/16" Nylock Nuts
7	2	HDW2056	5/16 x 2" Hex Bolts
8	2	HDW7056	5/16 Flange Nuts
9	2	HDW9420	5/8 x 1" Spacer

NOTE: Roller fairlead not included with this kit!

1. Remove the front bumper assembly.
2. Loosely bolt the top of the winch mount to the Ranger with the M10 x 35mm hex bolts (#3) into the existing weld nuts on the frame. See illustration for proper positioning.
3. Slide a spacer (#9) between the winch mount and frame at the lower mounting holes. Loosely secure in place using a 5/16" x 2" hex bolt (#7) and 5/16" flange nut (#8). Once in place, tighten all the nuts and bolts.
4. Position your winch on the mount and bolt in place from the bottom using the hardware that came with your winch.
5. Reinstall the front bumper assembly. Check to make sure you have clearance between the bumper and winch.
6. This mount accepts both standard and wide roller fairleads. If you have a WIDE roller fairlead or aluminum hawse (Warn 4000/4500, Superwinch Terra 45, or similar) you can simply bolt the fairlead/hawse to the existing holes in the front of the bumper over the top of the plastic insert piece. Install using the 5/16" x 3/4" hex bolts (#4) and 5/16" nylock nuts (#6). You may need to trim the plastic insert if the cable rubs on it. Pull the cable through the fairlead and install the hook.

If you have a STANDARD roller fairlead or aluminum hawse you will need to use the adapter brackets (#2). You will need to trim the opening in the plastic insert so the cable does not rub against it. Remove the plastic insert, use a cut-off wheel or sharp knife to make the opening large enough so the cable will not rub, and reinstall. Using a 5/16" x 1" hex bolt (#5) and 5/16" nylock nut (#6) bolt a fairlead adapter bracket to the front of the bumper over the plastic insert. The long side should face inwards. Repeat for the other side. Now bolt the roller fairlead or hawse to the fairlead brackets using the hardware provided with winch. Pull the cable through the fairlead and install the hook.

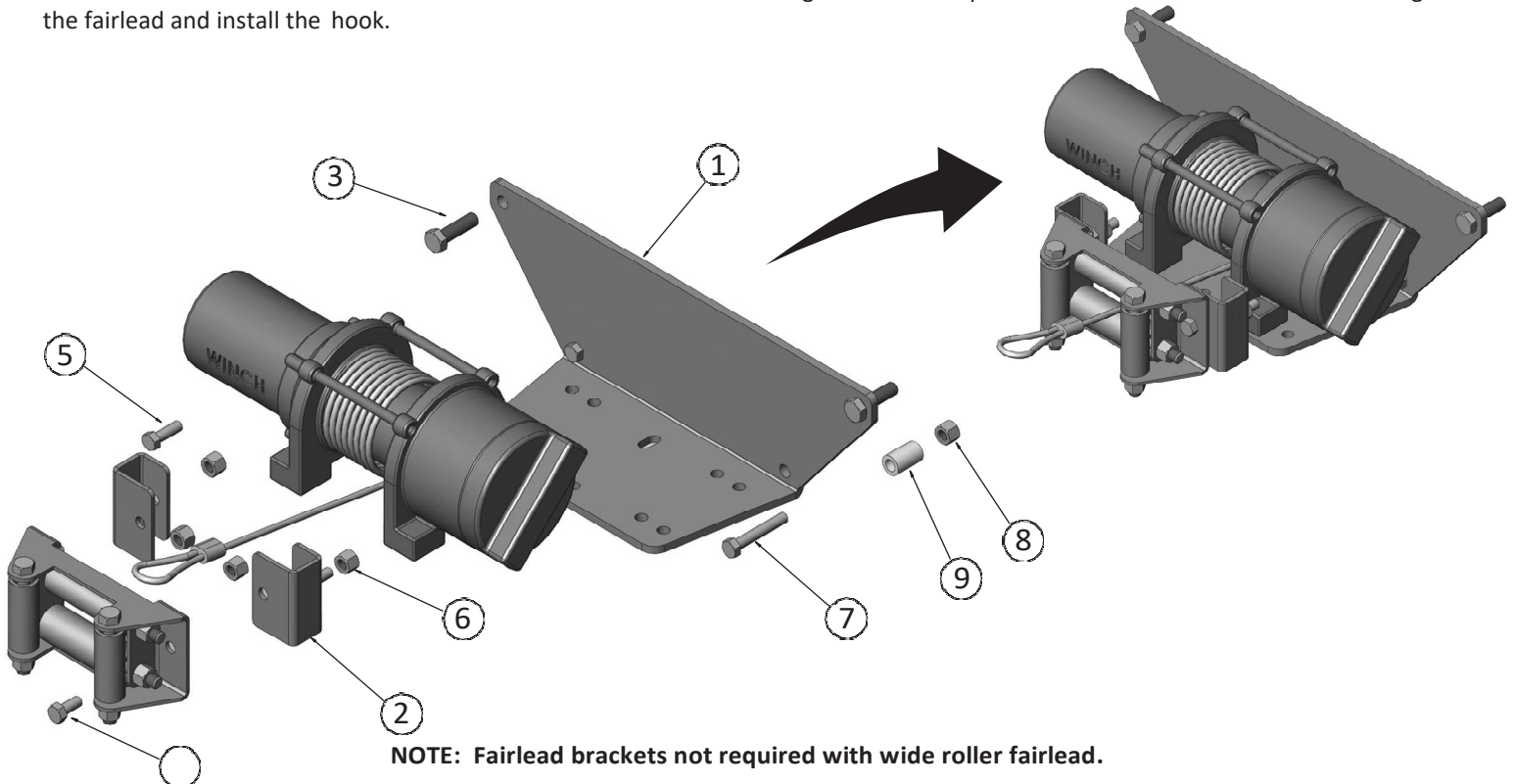

NOTE: Fairlead brackets not required with wide roller fairlead.

Questions or Comments call: 320-9645-1616 CST, 7:00 to 4:30 Mon. thru Thur.

INST1606

Winch Mount Instructions

Polaris Ranger 900 XP

PAGE 2

Mount will install in the top threaded holes and middle slot holes with spacers in between.



Bolt the winch in place using the hardware provided with your winch.



Winch mount properly installed.



Use the roller fairlead brackets if installing a standard size fairlead or hawse.

2019 models have fairlead location in front bumper so fairlead brackets may not be needed.