

Winch Mount Installation Instructions

Ref.	Qty.	Part #	Description
1	1	1616-01	Winch Mount Plate
2	2	HDW2050	5/16" x 3/4" Hex Bolts
3	2	HDW2100	3/8" x 1" Hex Bolts
4	2	HDW7058	5/16" Nylock Nuts
5	2	HDW7061	3/8" Nylock Nuts
6	4	HDW9001	3/8" Flat Washers
7	2	HDW9002	5/16" Flat Washers

NOTE: Roller fairlead not included with this kit!

14 – 19 YAMAHA VIKING / 14 - 19 VIKING VI

1. Place the mount in the front opening of the machine lining up the two holes in the bottom of the mount plate with the holes in the front bumper crossbar. Loosely bolt into place using two 5/16" x 3/4" hex bolts (#2), washers (#7) and nylock nuts (#4).
2. The rear arms of the mount will line up with an open hole in the vertical frame members underneath the upper a-arm mounts. Loosely bolt the rear mount arms to the frame using two 3/8" x 1" hex bolts (#3), four 3/8" flat washers (#6), and two 3/8" nylock nuts (#5). Once all the bolts have been started and the mount is straight you can tighten all the bolts.
3. There are multiple winch bolt patterns built into this mount to accommodate most winches. The winch will be placed on the mount angled forward. Make sure you mount the winch in the standard orientation with the cable coming off the bottom of the drum. Hold your winch on the mount and start the bolts by hand from the backside. You will use the bolts that came with your winch. Once all the bolts are started, tighten the winch down on the plate.
4. The winch mount has two sets of bolt holes to fit most roller fairleads or aluminum haswe's. Use whichever pattern lines up with your fairlead or hawse. Bolt in place using the hardware supplied with your fairlead.

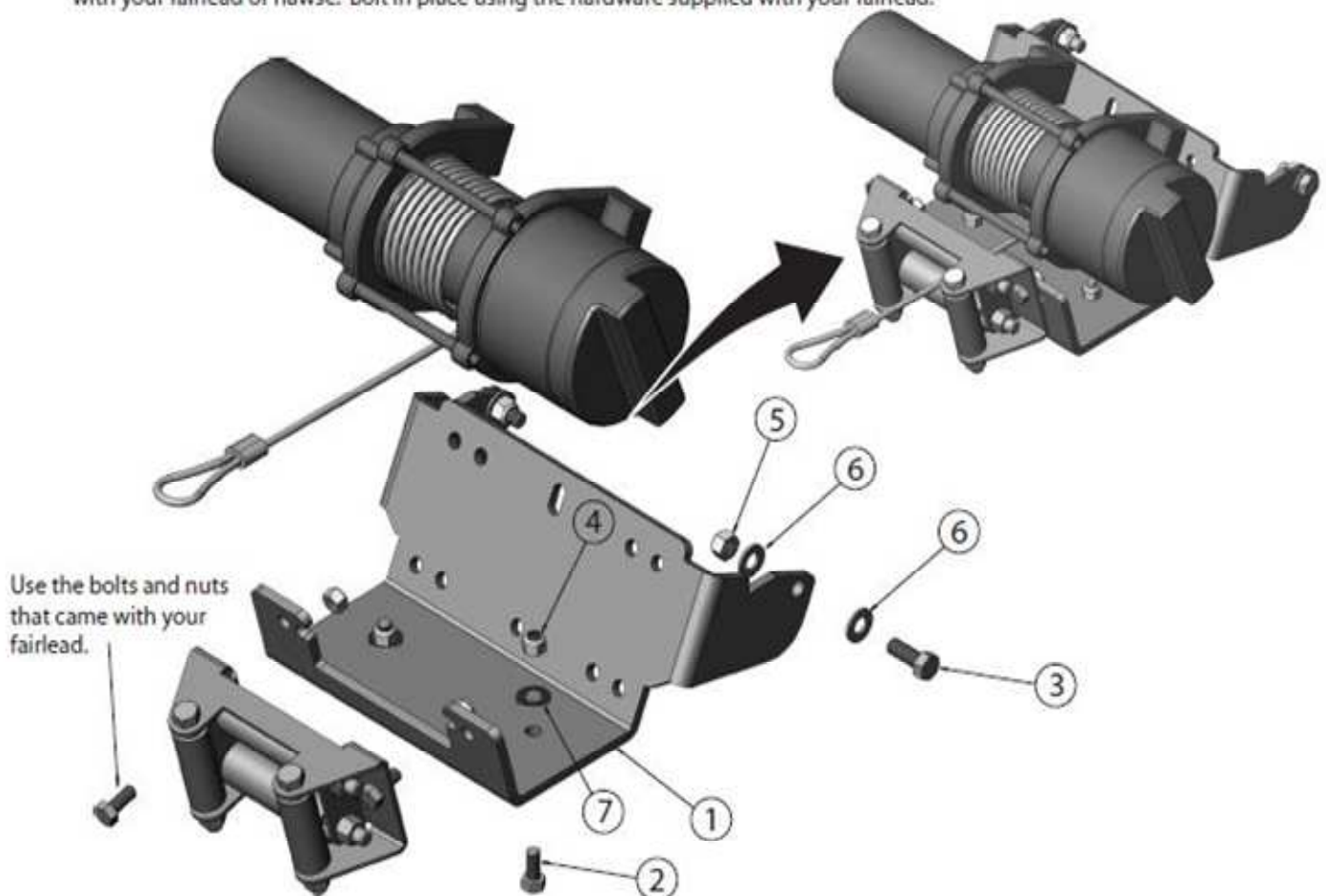

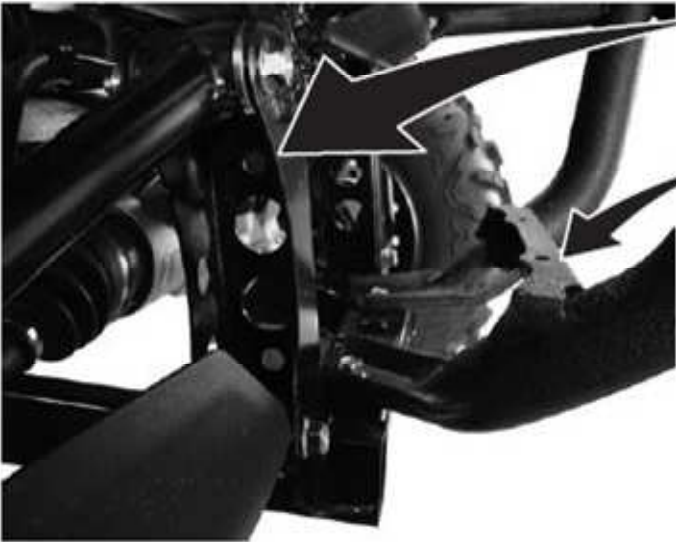

This is the hole that will be used to bolt the top rear arms of the mount plate to the frame.

Bolt the front of the winch mount plate through the holes in the front bumper cross member using two 5/16" x 3/4" hex bolts, flat washers and nylock nuts.

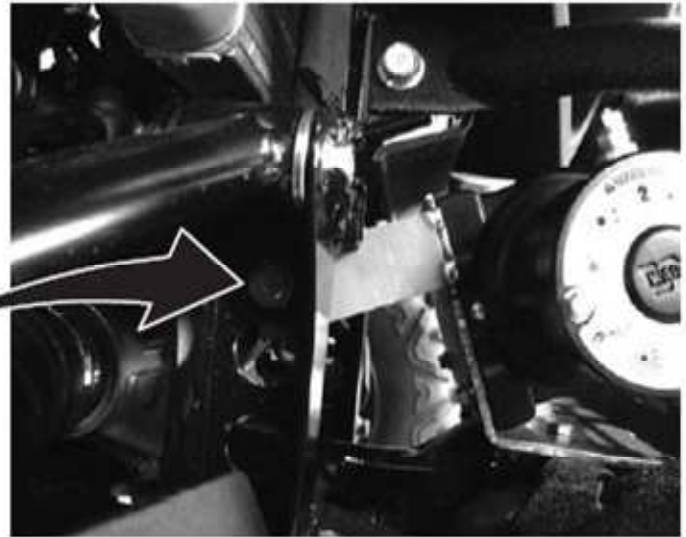

Bolt the rear arms to the frame using two 3/8" x 1" hex bolts, flat washers and nylock nuts.

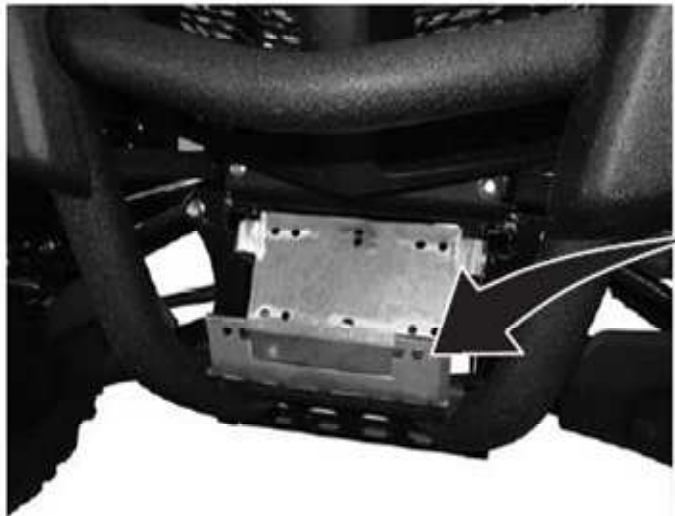

The roller fairlead can be installed in either set of bolt holes. Simply match up your fairlead with a set of holes and bolt in place using the hardware that came with your fairlead.



Completed installation.