

| ITEM | QTY. | PART#   | DESCRIPTION          |
|------|------|---------|----------------------|
| 1    | 1    | 1618-1  | Winch Mount Plate    |
| 2    | 1    | 1618-2  | Left Mount Bracket   |
| 3    | 1    | 1618-3  | Right Mount Bracket  |
| 4    | 10   | HDW7058 | 5/16 Nylock Nut      |
| 5    | 6    | HDW2050 | 5/16 x 3/4 Hex Bolts |
| 6    | 12   | HDW9002 | 5/16 Flat Washer     |
| 7    | 4    | HDW2051 | 5/16 x 1 Hex Bolt    |
| 8    | 4    | HDW1054 | 8mm x 25mm Hex Bolt  |

## WINCH MOUNT INSTALLATION INSTRUCTIONS POLARIS RANGER

1. Remove the factory front bumper from the machine. Remove the center screen out of the bumper. The mount kit and winch will install onto the bumper and then you will reinstall it to the machine.
2. Slide the main winch plate in place where you removed the center screen. Position it so the plate that extends back behind the bumper is facing up. The winch will hang upside down off of this plate. Bolt the two upper holes on the front of the winch mount to the bumper using two 5/16" x 3/4" hex bolts (#5) and 5/16" nylock nuts (#4). Use the two button head bolts that you removed to take off the center screen to install through the two remaining center holes in the front of the winch mount.
3. Install the right and left side brackets from the horizontal upper bumper brackets to the outer holes of the main winch plate. The side brackets will go on top of the main winch bracket. **NOTE:** the left and right side brackets are different, the holes on the short sides are offset, the longer side goes to the front of the machine. See illustration. Bolt the short side of each bracket to the outside of the horizontal bumper brackets using four 5/16" x 3/4 hex bolts (#5), 5/16" flat washers (#6), and 5/16" nylock nuts (#4).

**For all winches up to 3500# with the standard width drum:** Bolt the side plates to the main winch plate using four 5/16" x 1" hex bolts (#7), eight 5/16" flat washers (#6), and four 5/16" nylock nuts (#4). You can now install the winch placed upside down on the mount. 2 bolt pattern winches will use the two center holes and 4 bolt pattern winches will use the four remaining outer bolt holes. Pull some winch cable out through the fairlead hole. **NOTE:** Do not use the included 8mm x 25mm bolts included in this kit to mount your winch, use the hardware that came with your winch. The added length could cause the winch housing to crack if overtightened.

**For all 4000# and larger winches with the wide drum:** These winches will use the outermost holes in the mount and will hold all the brackets together. Using the four 8mm x 25mm hex bolts (#8) and washers (#) bolt the winch in place upside down through all mounting brackets. Pull some winch cable out through the fairlead hole.

4. The mount bracket accepts both size fairleads, you only need to use the set of holes that match up to your fairlead. Use hardware that came with your fairlead to mount up to winch mount. The bolts in illustration are not provided with winch mount any longer they now come in you winch box.

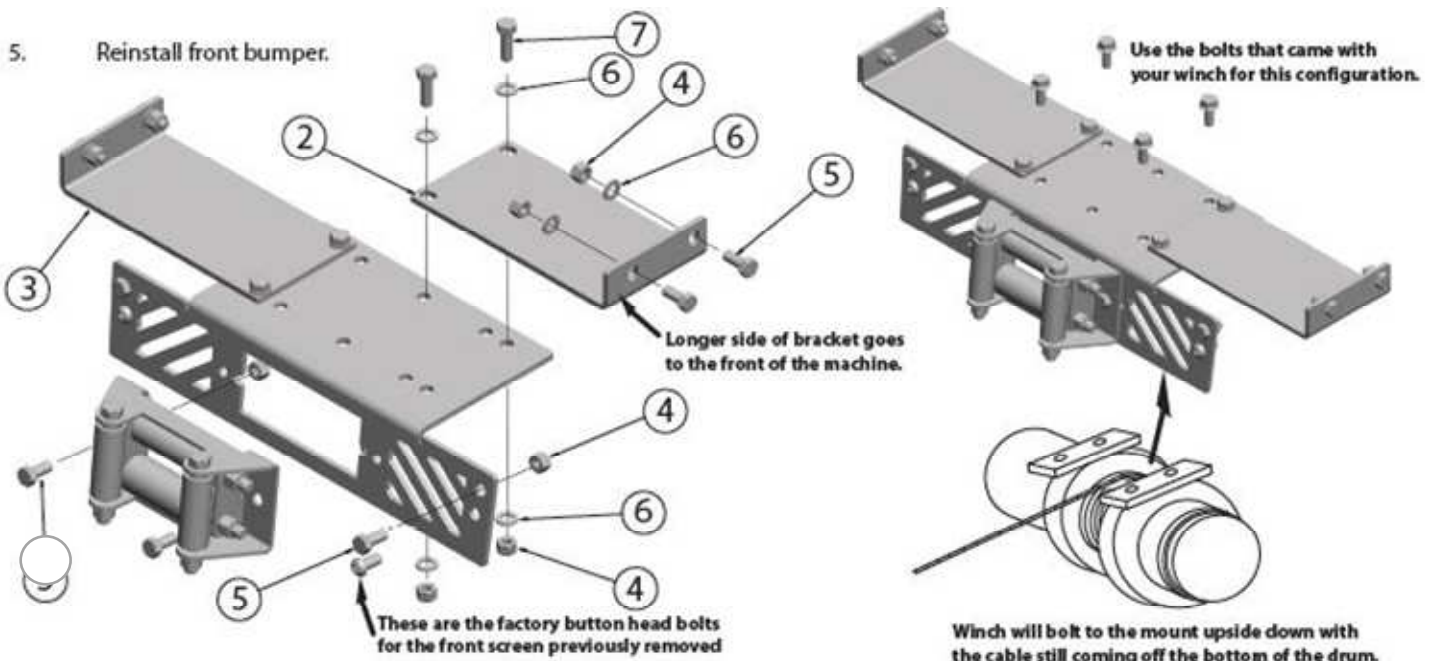

# Mount Installation Instructions

Page 2

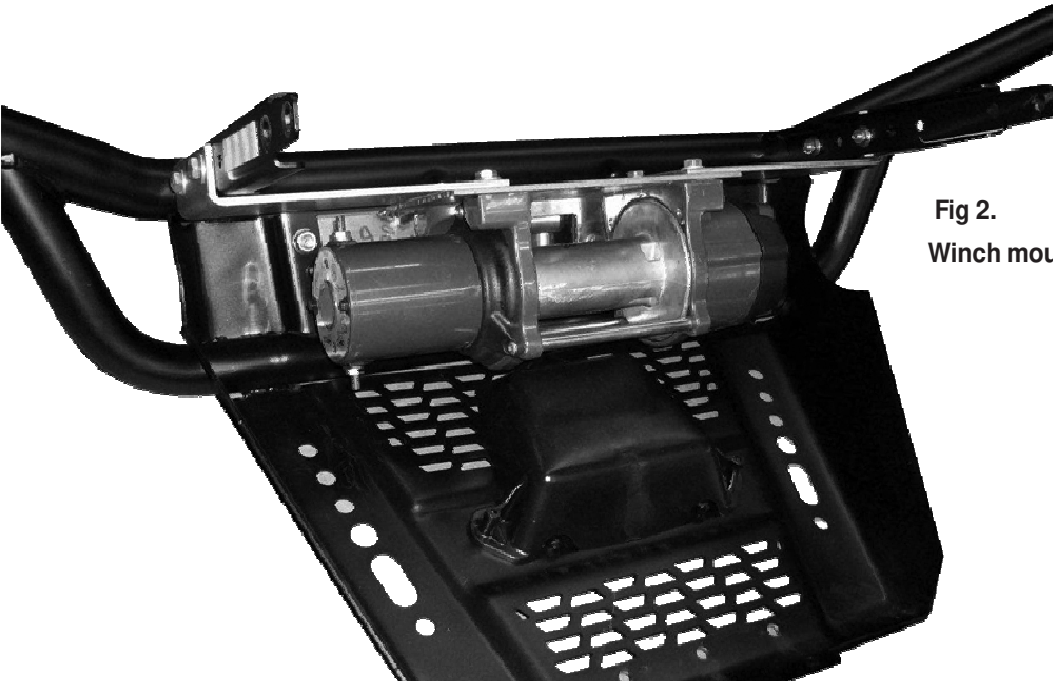

**Fig 2.**  
Winch mounted on inside of bumper.

When mounting on the 2016 ranger 570  
The bracket in Fig 3 will need to be switch  
From side to side for mounting, so the end  
With the gap will face the radiator.

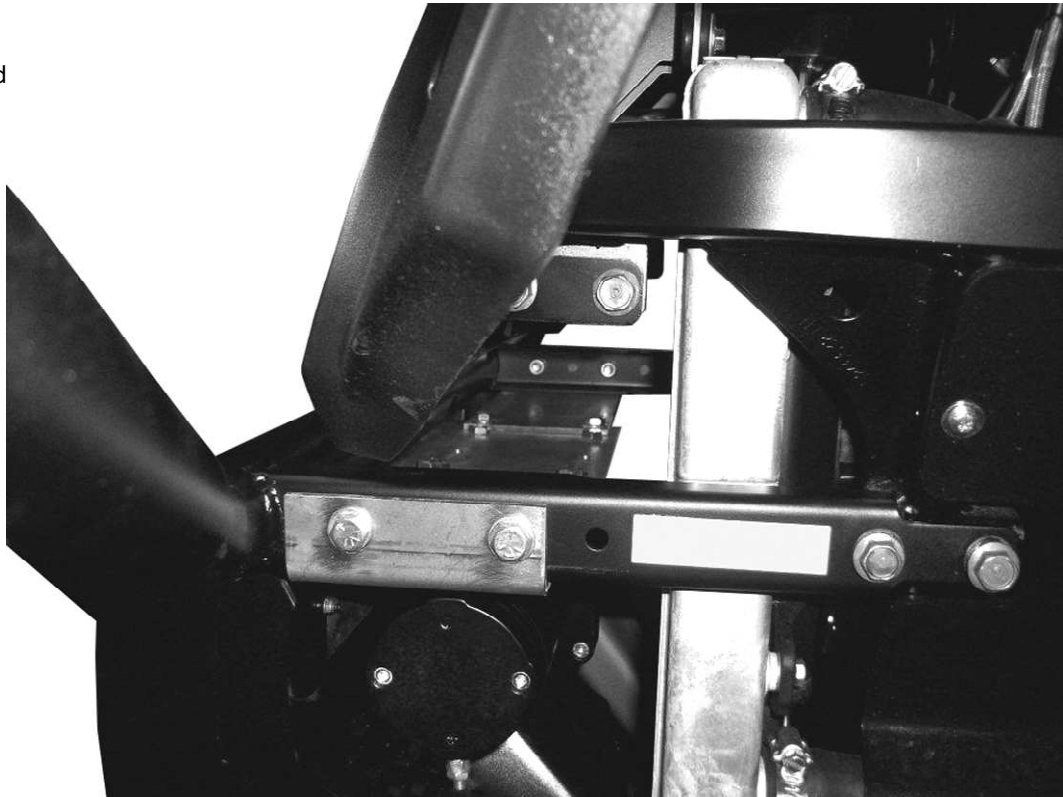

**Fig 3.**