

# Receiver Hitch

2009-15 Honda Rancher 420 AT (IRS)

2015 Honda Foreman Rubicon 500

Item	Qty.	Part#	Description
1	1	1180-70	1180 Receiver Hitch
2	1	HDW9056	3/4" Jam Nut
3	1	HDW9017	3/4" O.D. Flat Washer Spacer
4	2	HDW9427	1/4" Round Spacers
5	2	HDW1040	M10 Nylock Nuts
6	2	HDW1039	M10 x 75mm Hex Bolts

1. Remove the two stock ball hitch bolts. Leave the stock hitch in place on the machine.
2. Put the two spacers (#4) in place on the stock hitch where the bolts go through. Place the 3/4" flat washer spacer (#3) over the hole for the ball. Now set the receiver hitch in place on top of the spacers and stock hitch. The welded bolt on the receiver hitch goes through the 3/4" flat washer spacer and then into the hole for the ball.
3. Loosely bolt the back of the hitch together through the receiver, stock ball hitch, and frame using the M10 x 75mm hex bolts (#6) and M10 nylock nuts (#5).
4. Loosely secure the welded-on bolt to the stock hitch using the 3/4" jam nut (#2).
5. Once all the bolts are in place and the receiver is aligned, tighten all the bolts.

**DO NOT EXCEED THE MANUFACTURERS RECOMENDED TOWING OR TONGUE WEIGHT CAPACITY! THIS HITCH WILL OUTPERFORM FACTORY TOWING/WEIGHT CAPACITIES SO BENT OR BROKEN HITCHES WILL NOT BE WARRANTED.**

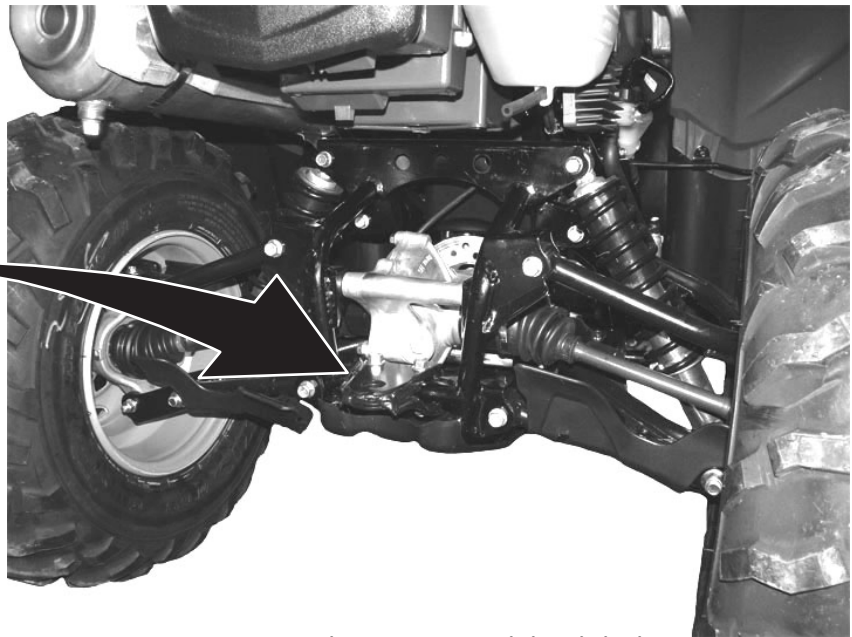
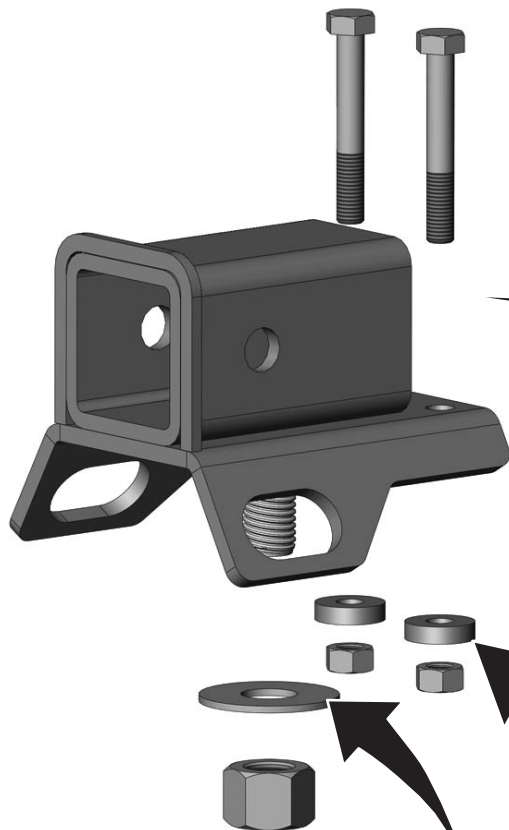

Remove these two stock hitch bolts, position the spacers and washer in place over the stock hitch, place the receiver hitch on top of the spacers and bolt in place using the supplied 10mm x 75mm bolts and nuts.

This washer and spacers go between the receiver hitch and stock hitch.

FOR QUESTIONS or COMMENTS CALL 320-964-1616 Monday thru Thursday 7:00 to 4:30 CST  
Inst1180